

INSTALLATION, WARNINGS, AND OPERATION INSTRUCTIONS

FLEXCON COMPOSITE WELL TANKS

OPERATION

This well tank has been designed to store and deliver water under pressure between pump cycles in a domestic water system. It features a patented Controlled Action Diaphragm (CAD2) system that completely contains the system water in a safe NSF approved chamber. The CAD2 system prevents water from ever touching the internal walls of the tank which greatly reduces external condensation.

WHAT IT DOES

Without a storage tank, a domestic water system's pump would cycle (turn on) every time there was a demand for water. This frequent and potentially short cycling would shorten the useful life of the pump. Flexcon well tanks are designed to store water when the pump is running and then deliver pressurized water back to the system when the pump is shut off. A properly sized well tank will store at least one gallon of water for every gallon per minute (GPM) of pump capacity. This allows for fewer pump starts and longer run times which should maximize the life of the pump.



THIS IS THE SAFETY ALERT SYMBOL. IT IS USED TO ALERT YOU TO POTENTIAL PERSONAL IN-JURY HAZARDS. OBEY ALL SAFETY MESSAGES THAT FOLLOW THIS SYMBOL TO AVOID POSSIBLE INJURY OR DEATH.

INDICATES A POTENTIALLY HAZARDOUS SITUATION WHICH, IF NOT AVOIDED, COULD RESULT IN SERIOUS INJURY, DEATH, AND/OR SIGNIFICANT PROPERTY DAMAGE.

WARNING

This product must be installed by a **Qualified Professional** following all local and national plumbing and electrical codes. Read and understand fully the instructions included here and those on the Flexcon website which are updated on a regular basis. This product must be inspected annually by a qualified professional for any signs of corrosion or leakage and replaced immediately if these signs are present. Failure to follow these instructions may result in serious injury, death and/or property damage and will void the product warranty.

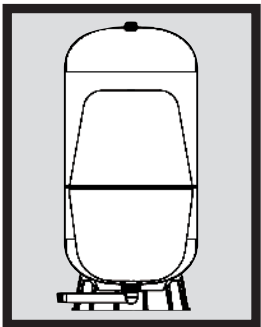

WARNING

EXPLOSION HAZARD This well tank is designed for water storage at a maximum pressure of 125 psi and a maximum temperature of 120 F. A properly sized pressure relief valve set at a maximum of 100 psi must be installed in the system. This tank is shipped with a pre-charge of 38 psi and any adjustment to the pre-charge must be done prior to installation and at ambient temperature. Do not adjust the pre-charge of this tank if the product is corroded or damaged or shows any signs of diminished integrity. The maximum allowable pre-charge in this expansion tank is 80 psi. Failure to follow these instructions is UNSAFE and may result in serious injury, death and/or property damage.

WARNING

This well tank and the associated piping will in time leak. This tank must be installed in a location where water leakage will not cause property damage and there must be means for adequate drainage. This tank must not be installed in a location that is subject to freezing. This tank must be installed in the vertical position. The manufacturer of this product is not liable or responsible for any water damage associated with the installation and or failure of this product. Failure to follow these instructions may result in serious injury, death and/or property damage.

WARNING

This tank is intended for use on potable water systems only and any other use may be dangerous and will void the warranty. This products performance and lifespan can be significantly impacted by aggressive water conditions. A water test should be conducted specifically looking for corrosive water, acids and other relevant water contaminants which if present must be treated appropriately. The system piping must be properly grounded to earth. A dielectric union may be required in the system. Failure to follow these instructions may result in serious injury, death and/or property damage.

WARNING

CALIFORNIA PROPOSITION 65 **WARNING!** This product contains a chemical known to the State of California to cause cancer and birth defects or other reproductive harm. (California installer-California law requires that this notice be given to the consumer/end user of the product). For more information, contact the manufacturer at www.flexconind.com.

These instructions and warnings are subject to periodic updates on the Flexcon website, www.flexconind.com, and should be regularly reviewed by the consumer for important safety and instruction updates.



BEFORE INSTALLATION

PRE-CHARGE ADJUSTMENT

This well tank is shipped from the factory with a pre-charge of 38 psi. The well tank should be pre-charged to 2 PSI below the cut-in setting of the pressure switch but must not exceed 80 psi. Any adjustments to the factory pre-charge must be done prior to initial tank installation and with 0 psi pressure on the system. **DO NOT ADJUST THE PRE-CHARGE OF THE EXPANSION TANK WITH THE SYSTEM UNDER PRESSURE!**

TO ADJUST TANK PRECHARGE (Prior to Installation)

Remove the protective cap from the air valve.

Check the tank pre-charge pressure using a standard tire pressure gauge.

If required add air to the tank using a manual bicycle tire pump until the proper pre-charge pressure is reached.

Replace the protective cap on the air valve.

TO ADJUST TANK PRECHARGE (After Installation)

Disconnect power to the system pump.

Drain the tank of water by opening a faucet

Add or release air as required (see above)

WARNING

Do not adjust the tank air pressure if there are any visible signs of corrosion on the tank. If this well tank shows any visible signs of corrosion or rusting, the tank must be replaced immediately. Failure to follow these instructions may result in serious injury, death and/or property damage.

INSTALLATION

LOCATION

Select a location where a water leak will not cause property damage and provides adequate means for water drainage. This well tank and the associated piping will in time leak. The manufacturer is not responsible for any water damage that may occur in association with the well tank installation. The tank location should be as close as possible to the system pressure switch to reduce the negative effects of friction/elevation pressure loss. This tank has been designed to be mounted on a level surface and must be adequately supported around the entire base.

WARNING Disconnect or shut off the electrical power source to the system pump. Shut off the water supply to the system and remove all water pressure from the system. Failure to follow these instructions may result in serious injury, death and/or property damage.

Install the well tank in the incoming water line from the pump and before any fixtures (see Fig. 1). Adequate thread sealant (pipe dope) must be added to ensure a leak free installation.

WARNING A properly sized pressure relief valve set at a maximum of 100 psi must be installed in the system.

Before turning on the water supply to the system, open a water faucet to allow air from the system piping to be released. Turn on the power to the water supply and the pump should turn on, filling the system piping. When the water is flowing freely from the faucet without air, close the faucet. The pump will continue to run filling the well tank. Inspect the installation for water leaks paying close attention to the connection between the well tank and the system piping.

TYPICAL INSTALLATION

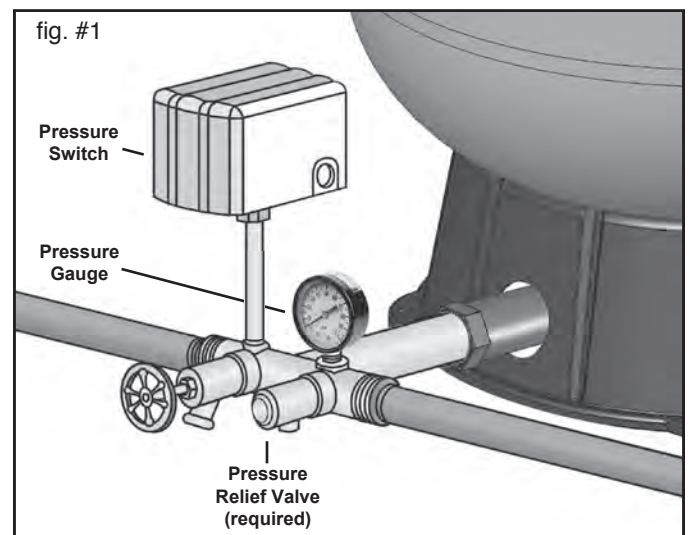

MAINTENANCE

- This well tank and the entire system must be checked annually by a qualified professional.
- Visually examine the tank and its connection to the system piping looking for any signs of water leakage or corrosion on the exterior of the tank or the connection.

MULTI TANK INSTALLATION

All of the tanks must have the same pre-charge for the system to function properly. Adjust each tank's pre-charge as detailed on page 2. The system pressure switch or control should be centrally located (see diagram) in order for the tanks to function properly.

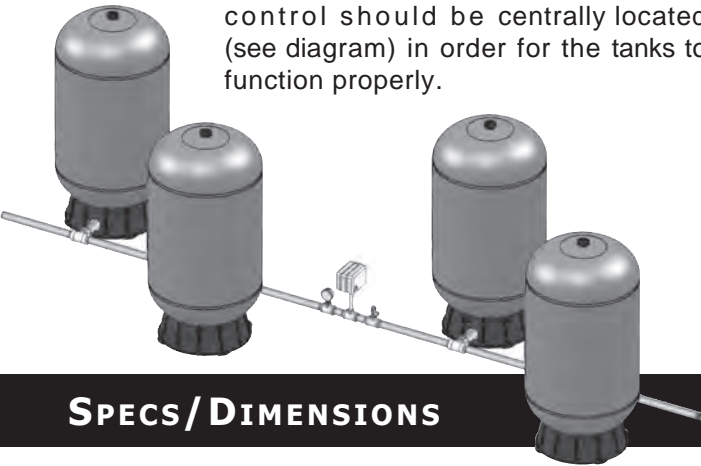

SPECS/DIMENSIONS

MATERIALS OF CONSTRUCTION

- *Top and bottom domes: Injection molded copolymer polypropylene*
- *Shell: Extruded copolymer polypropylene*
- *Outer shell: Fiberglass-wound, coated with epoxy resin*
- *Water chambers: Top diaphragm is 100% butyl rubber, lower water chamber is copolymer polypropylene*
- *Base: Copolymer polypropylene*
- *Connection: Rigid Schedule 80 PVC*
- *Air valve: Brass valve with o-ring seal*
- *Warranty: 5 year limited*

COMPOSITE TANK DIMENSIONS

Total Tank Volume		A Height		B Floor to CL		C Diameter		D CL to fitting end		E Connection	Total Weight	
gal	liters	in	cm	in	cm	in	cm	in	cm		lbs	kilos
15	56.8	25.6	64.0	1.75	4.4	16.5	41.9	9.4	23.9	1" NPT	19.0	8.6
22	83.3	34.1	84.1	1.75	4.4	16.5	41.9	9.4	23.9	1" NPT	24.0	10.9
35	132.5	48.9	121.7	1.75	4.4	16.5	41.9	9.4	23.9	1" NPT	33.5	15.2
38	143.8	29.75	74.7	2.25	5.7	24.2	61.5	11.9	30.2	1 1/4" NPT	38.0	15.9
50	189.3	43.3	109.0	2.25	5.7	21.4	54.4	11.9	30.2	1 1/4" NPT	47.0	21.3
65	246.0	51.3	129.3	2.25	5.7	21.4	54.4	11.9	30.2	1 1/4" NPT	58.0	26.3
82	310.4	64.7	163.3	2.25	5.7	21.4	54.4	11.9	30.2	1 1/4" NPT	69.5	31.5
90	340.7	57.0	143.8	2.25	5.7	24.2	61.5	13.4	34.0	1 1/4" NPT	77.0	34.9
119	450.4	72.1	182.1	2.25	5.7	24.2	61.5	13.4	34.0	1 1/4" NPT	99.5	45.1

Maximum working pressure 125 psig. Maximum working temperature, internal & external 120° F. Tank pre-charge 38 psig.

UNDERGROUND INSTALLATION

The Flexcon BG series has a specially formulated exterior finish for direct burial in the ground below the frost line. Adjust tank pre-charge prior to burial. Ensure that the tank will be buried above the water table and below the frost line. The tank should be embedded in coarse sand above crushed stone. To minimize stress on the tank and connection in the event of shifting of the sand surrounding the tank, we recommend the use of a swing joint connection (see diagram). Make sure to completely backfill the hole with sand and compact to prevent tank settling. Permanently mark and identify the location of the tank.

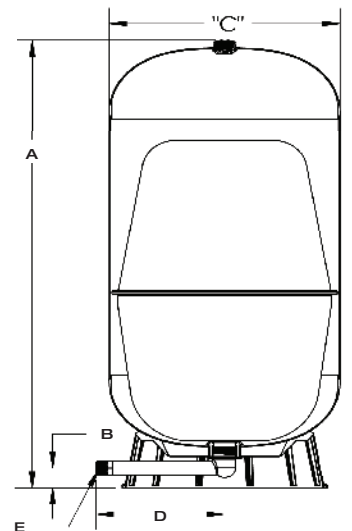
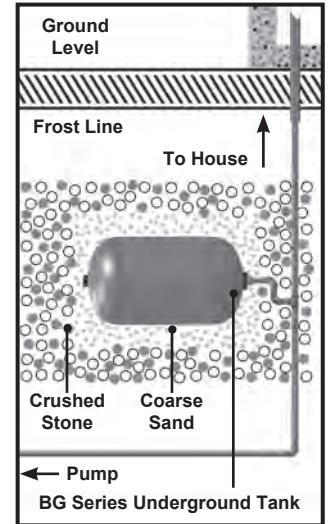

FLEXCON INDUSTRIES LIMITED PRODUCT WARRANTY

PRODUCTS COVERED: COMPOSITE WELL TANKS MANUFACTURED AND DISTRIBUTED BY FLEXCON INDUSTRIES

Important: Read carefully the installation, operating and maintenance instructions manual ("Manual") to avoid serious personal injury and/or property damage and to ensure safe use and proper care of this Product.

Warranty - Warranty is extended to all purchasers of the new product. The warranty is non-transferable. Flexcon warrants to the purchaser or first user of the new Product that at the time of manufacture, the Product is free from defect in material or workmanship for five (5) years from the date of manufacture. Any warranty claim must be made within five (5) years (unless another time period is set forth in the Manual), measured from the date of manufacture.

In the event of a breach of the foregoing warranty and upon proper and timely notification to Flexcon, Flexcon will at its option either: make repairs to correct any defect in material or workmanship, or supply and ship either new or used replacement parts or products. Flexcon will not accept any claims for, nor will Flexcon be responsible for, any other costs including labor.

Exclusions - This warranty does not cover any failure or problem unless it was caused by a defect in material or workmanship. In addition, this warranty shall not apply:

- If the Product is not correctly installed, operated, repaired or maintained as described in the Manual provided with the Product.
- To any failure or malfunction resulting from (i) misuse or abuse, (ii) improper or negligent handling, shipping (by anyone other than Flexcon), storage, use or operation, or (iii) damages to the tank caused by lightning, floods, fire, freezing or any other environmental condition.
- To damages caused by any unauthorized alteration to the Product, or any attempt to repair tank leaks or parts.
- To any failure or problem resulting from the use of the Product for any purpose other than those specified in the Manual.
- If the Product is used anywhere except the United States, its territories or possessions, or Canada.
- To labor costs, shipping charges, service charges, delivery expenses, administrative fees or any costs incurred in removing or reinstalling the Products.
- To any claims submitted to Flexcon or a Flexcon authorized distributor or dealer more than 30 days after expiration of the applicable warranty time period described in this Warranty.
- To any repair or replacement costs not authorized in advance by Flexcon.

Warranty Limitations - All implied warranties including the implied warranties of merchantability and fitness for a particular purpose are specifically disclaimed.

Limitations of Remedies - The remedies contained in this warranty are the purchaser's or first user's exclusive remedies. In no circumstances will Flexcon be liable for more than, and purchaser-first user's remedies shall not exceed, the price paid for the Product. In no case shall Flexcon be liable for any special, indirect, incidental or consequential damages, whether resulting from non-delivery or from the use, misuse, or inability to use the Product or from defects in the product or from Flexcon's own negligence or other tort. These exclusions apply regardless of whether such damages are sought for breach of warranty, breach of contract, negligence, strict liability, in tort or under any other legal theory. Excluded damages include, but are not limited to, inconvenience, loss or damage to property, mold, loss of profits, loss of savings or revenue, loss of use of the Products or any associated equipment, facilities, buildings or services, downtime, and the claims of third parties including customers.

What To Do If You Have a Problem Covered By This Warranty - You must notify the authorized Flexcon distributor or dealer who sold you the Product within 30 days of the event leading to the Warranty claim. Any covered Warranty service must be authorized by the Flexcon distributor or dealer which sold you the Product. If you do not receive a prompt response, call Flexcon directly at 781.986.2424. Notice of a Warranty claim should be submitted within 60 days of the event leading to the claim by the authorized distributor/dealer to Flexcon at the following address:

Flexcon Industries, Warranty Claim Dept., P.O. Box 782, Randolph, MA 02368

Before Flexcon determines to provide any replacement part or Product, it may, as a pre-condition to making such a determination, require that the warranty claimant ship the Product, postage prepaid, to an authorized Flexcon distributor, or to Flexcon, and provide proof of purchase evidenced by the original sales receipt.

Replacement Product Warranty - In case of replacement of a Product or any component part, Flexcon reserves the right to make changes in the design, construction, or material of the substitute components or products, which shall be subject to all of the terms and limitations of this Warranty, except that the applicable warranty periods shall be reduced by the amount of time the warranty claimant owned the product prior to submitting notification or the warranty claim.

Owners Record Keep for later use

Serial number (see tank data label at bottom of tank): _____

Model (see tank data label at bottom of tank): _____

Date Installed: _____

Installer Name: _____

Telephone number: _____

Retain copy of cancelled check and installation receipt

